



Reverse Engineering

Alexander Sotirov
alex@sotirov.net



NYU·poly
POLYTECHNIC INSTITUTE OF NYU



Part I

What is reverse engineering?

Computer Underground



- Cracking software copy protection
 - PC software and games
 - modding the Xbox and Playstation
- Exploit development
 - advanced exploitation
- Reversing undocumented operating system APIs
 - virus writers
 - spyware, keyloggers, malware, rootkits

Security Industry



- Virus and malware analysis
 - AV and Anti-Spyware companies
 - forensics
- Patch analysis, vulnerability analysis
 - IDS, IPS companies
- Binary code auditing
 - discovering new vulnerabilities
- Exploit development
 - penetration testing

Roadmap for today



The goal for today: turn a x86 binary executable back into C source code.

- x86 assembly in 10 minutes
- compiler design and code optimizations
- binary reverse engineering

We'll use the IDA Pro disassembler and a sample executable from a reversing contest.



Part II

x86 assembly in 10 minutes

CPU architecture

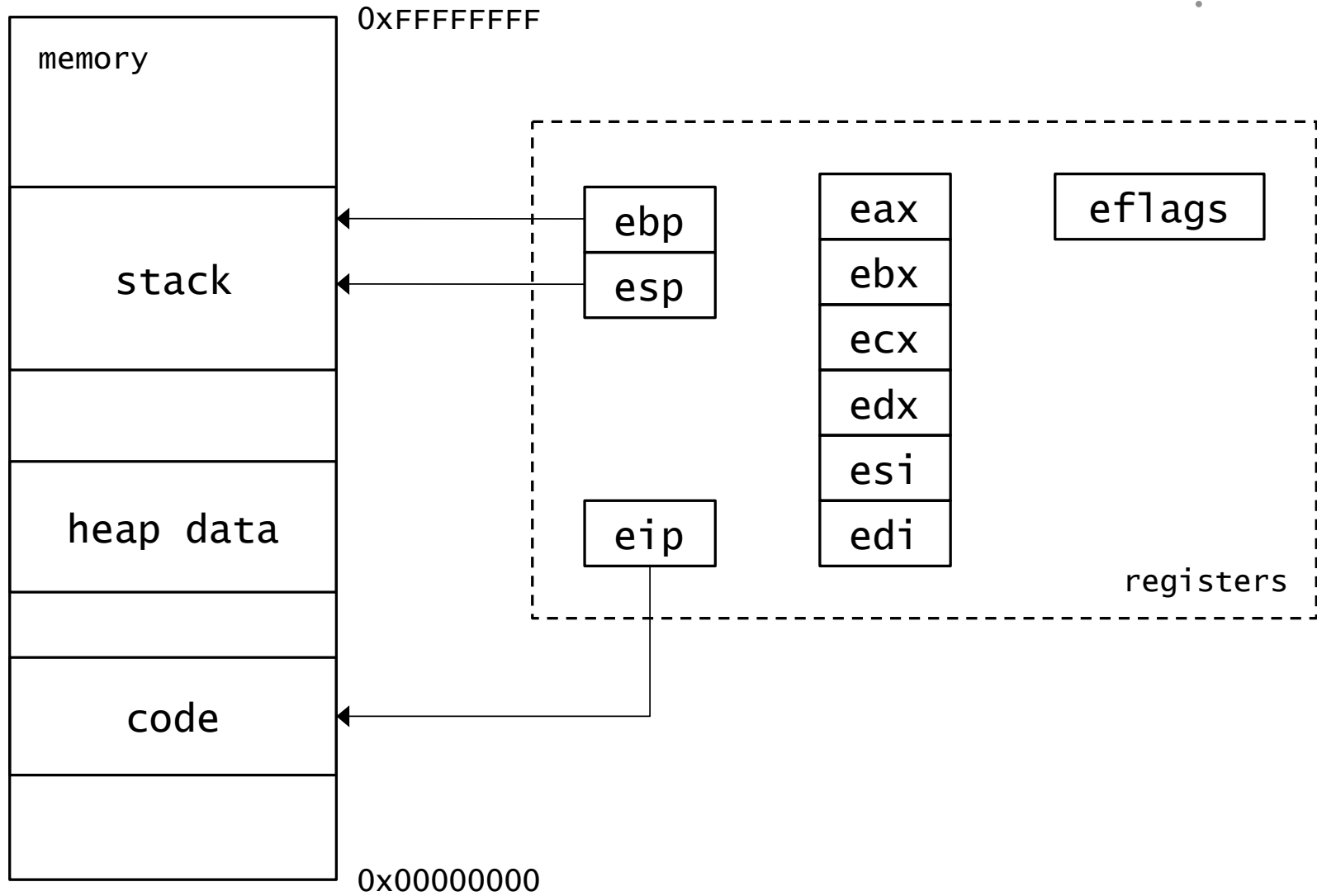

Arithmetic instructions



mov eax, 2 ; eax = 2

mov ebx, 3 ; ebx = 3

add eax, ebx ; eax = eax + ebx

sub ebx, 2 ; ebx = ebx - 2

Accessing memory

mov eax, [1234] ; eax = *(int*)1234

mov ebx, 1234 ; ebx = 1234

mov eax, [ebx] ; eax = *ebx

mov [ebx], eax ; *ebx = eax

Conditional branches



`cmp eax, 2` ; compare eax with 2

`je label1` ; if (eax == 2) goto label1

`ja label2` ; if (eax > 2) goto label2

`jb label3` ; if (eax < 2) goto label3

`jbe label4` ; if (eax <= 2) goto label4

`jne label5` ; if (eax != 2) goto label5

`jmp label6` ; unconditional goto label6

Function calls

```
call func      ; store return address on  
               ; the stack and jump to func
```

func:

```
    push esi   ; save esi  
    ...  
    pop esi    ; restore esi  
    ret       ; read return address from  
               ; the stack and jump to it
```



Part III

Compiler design and code optimizations

Modern compiler architecture

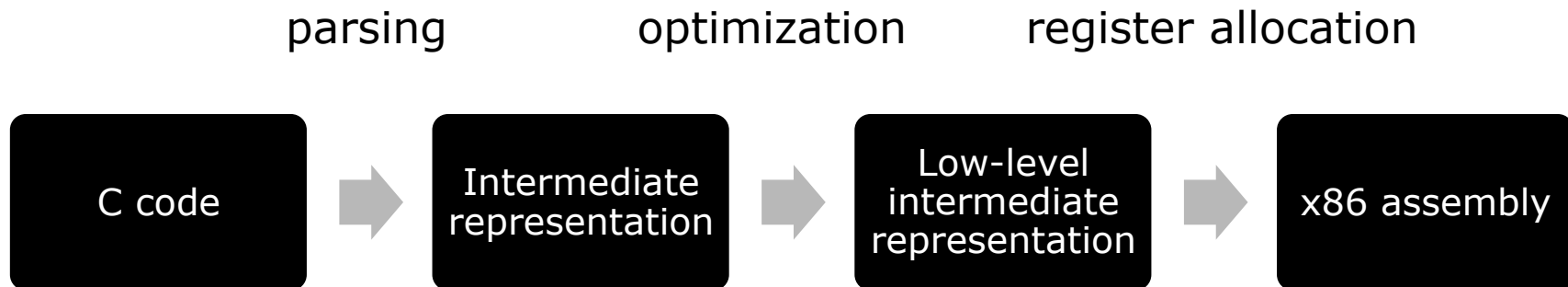

High-level Optimizations



- Inlining
- Loop unrolling
- Loop-invariant code motion
- Common subexpression elimination
- Constant folding and propagation
- Dead code elimination

Inlining

```
int foo(int a, int b) {  
    return a + b;  
}
```

```
c = foo(a, b+1);
```

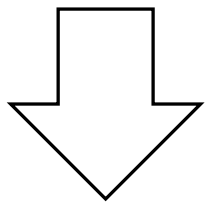

```
c = a + b + 1;
```

Loop unrolling

```
for (i = 0; i < 2; i++) {  
    a[i] = 0;  
}
```

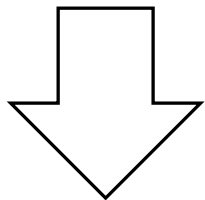

```
a[0] = 0;  
a[1] = 0;
```

Loop-invariant code motion

```
for (i = 0; i < 2; i++) {  
    a[i] = p + q;  
}
```

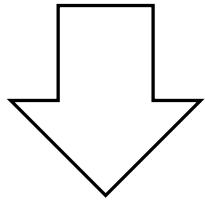

```
temp = p + q;  
for (i = 0; i < 2; i++) {  
    a[i] = temp;  
}
```

Common subexpression elimination

$$a = b + (z + 1)$$

$$p = q + (z + 1)$$

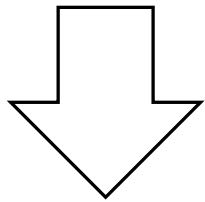

$$\text{temp} = z + 1$$

$$a = b + z$$

$$p = q + z$$

Constant folding and propagation

`a = 3 + 5`

`b = a + 1`

`func(b)`

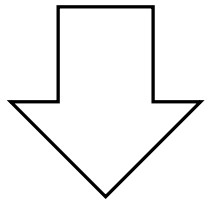

`func(9)`

Dead code elimination

```
a = 1
if (a < 0) {
    printf("ERROR!")
}
```

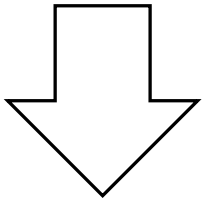

```
a = 1
```

Low-level optimizations



- Strength reduction
- Code block reordering
- Register allocation
- Instruction scheduling

Strength reduction

$$y = x * 2$$

$$y = x * 15$$

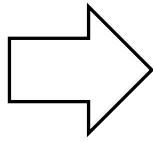

$$y = x + x$$

$$y = (x << 4) - x$$

Code block reordering

```
if (a < 10) goto l1
printf("ERROR")
goto label2
l1:
printf("OK")
l2:
return;
```

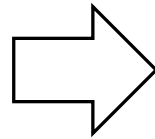

```
if (a > 10) goto l1
printf("OK")
l2:
return
l1:
printf("ERROR")
goto l2
```

Register allocation



- Memory access is slower than registers
- Try to fit as many local variables as possible in registers
- The mapping of local variables to stack locations and registers is not constant

Instruction scheduling

```
mov eax, [esi]
add eax, 1
mov ebx, [edi]
add ebx, 1
```

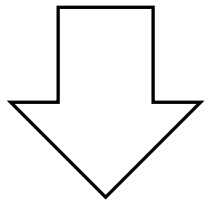

```
mov eax, [esi]
mov ebx, [edi]
add eax, 1
add ebx, 1
```



Part IV

Binary reverse engineering

Overview



We need to understand:

- How the compiler turns C code into assembly code
- Low-level OS structures and executable file format

We need to think like the compiler, but in reverse!

Tools

IDA Pro disassembler from hex-rays.com

Limited demo and freeware versions are available.

Almost no documentation!

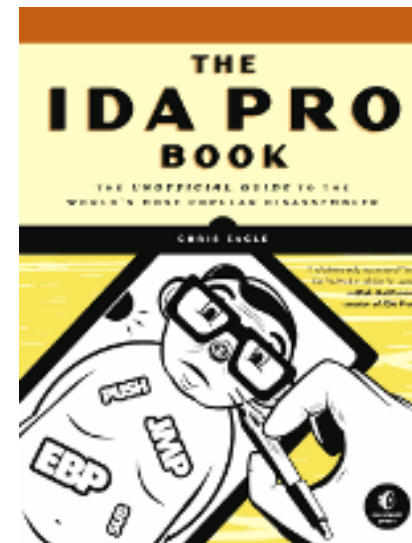



Diving into IDA Pro